



BATH TOWNSHIP ZONING

Summit County, Ohio

3864 West Bath Road - P.O. Box 1188 - Bath, Ohio - 44210-1188
Phone: 330.666.4007 - Fax: 330.666.0305
www.bathtownship.org

APPEARANCE REVIEW COMMISSION

For office use only:	ARC File No.:	BZA File No.:
Associated permits:		

Applicant Data

Name: Erick Allen

Company Name: Alber & Rice

Address: 31913 Cook Road North Ridgeville Ohio 44039

Telephone No.: 330-697-0379 Email: erick@alberandrice.net

Property Data

Zoning District: (circle one) R-1 R-2 R-3 R-4 B-1 B-2 B-3 B-4 B-5

Corner Lot: Yes No Note: Corner lots are required to meet the front setback on both streets.

Property Address: 3979 Medina Road Akron Ohio 44333

Allotment Name: _____ Parcel No.: _____

Owner(s): Albrecht Incorporated

Owner Address: 17 S. Main Street, Suite 401 Akron Ohio 44308

Telephone No.: 330-344-9107

Type of Review (check all that apply)

- Site Plan
- Building/Elevation
- Sign
- Other (explain): _____

Required Site Plan Data and Architectural Drawings

The following items must be submitted with the application in order to be reviewed. A digital copy of site plan and plans will be required upon submission. (The application will be reviewed and placed on the agenda for review by the ARC once the application is deemed complete)

- 1 copy of site plan – must show existing structures, proposed structures, all setbacks and lot dimensions, driveway access location, all easements, septic system and well location (if applicable), and any unusual topography (include streams, lakes, ponds, ravines, steep slopes, etc.)
- 1 copy of elevations, signs, landscaping, lighting, parking, etc.
- Digital copy of all required documents (i.e. .pdf file)

Fee – Due at time of application (make check payable to Bath Township Trustees)

- For Site Plan - \$100.00

Applicant Signature:  Date: 9/25/2025



Actual image of a 38' x 40' arch building, wood post foundation shown

NOTE: Proposed building will be 38' x 32'. Proposed building will have a 4' concrete block foundation (similar to the two salt buildings that ACME currently has behind the store)

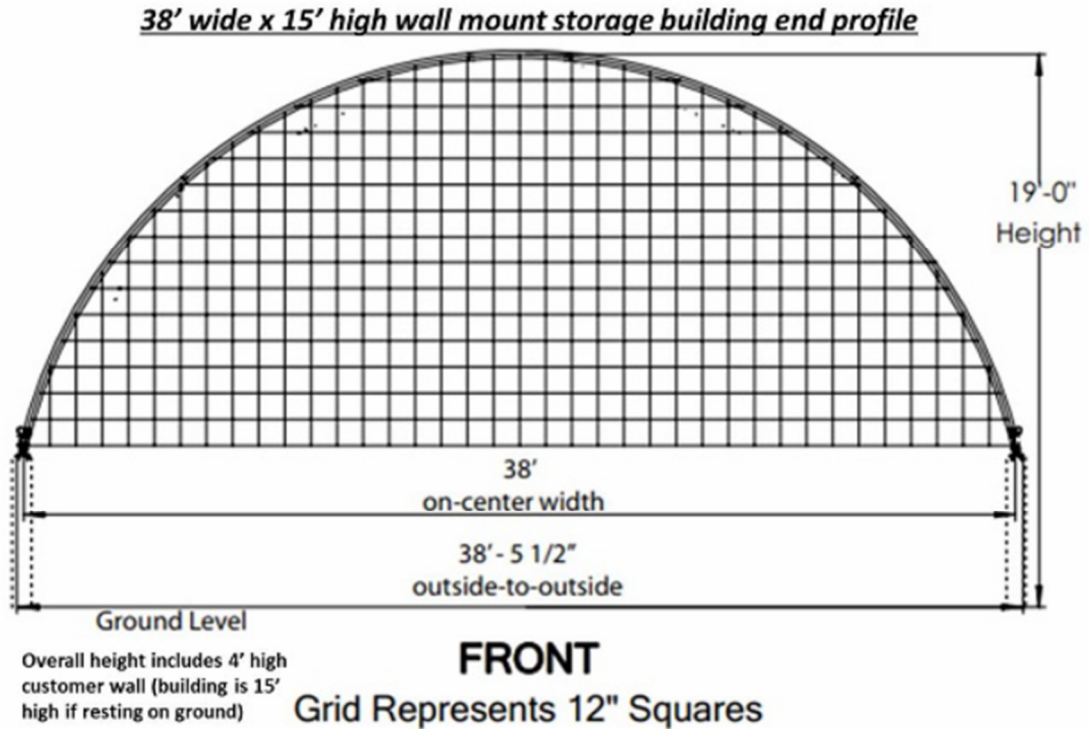

Front dimensions of 38' wide building on 4' concrete wall foundation

Visit Rasmar Industries to learn more about the building styles